

HOLE SAW CONFIGURATION

To prevent possible damage to internal components equip hole saws with depth stop, as illustrated below. Remove and inspect behind panels for internal components prior to drilling each hole.

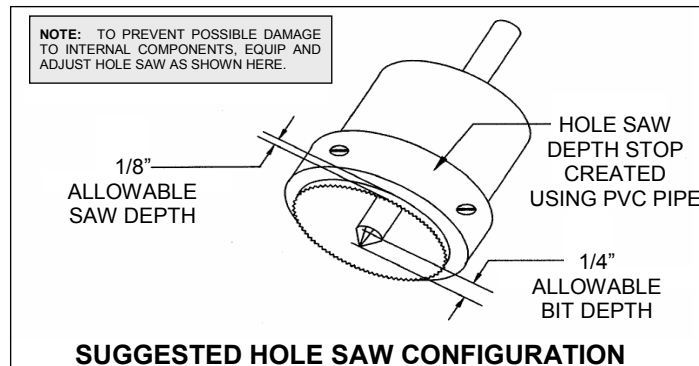

Using PVC pipe as shown in the photo above a hole saw depth stop can be created. The 1-5/8" hole saw depth stop is created using 1-1/2" PVC and the 1-3/8" hole saw depth stop is created using 1-1/4" PVC pipe. A small bolt and nut are used to secure the pipe to the hole saw. Hole saws and pipe can be purchased from a plumbing wholesale house or your local hardware store.



Trent Technologies, Inc.

15939 FM 2493 (Old Jacksonville Highway)
Tyler, Texas 75703
PHONE: (903) 509-4843, FAX: (903) 534-8212

www.TrentTech.com

Copyright © 1993-2005 Trent Technologies, Inc., all rights reserved